

Perma Lamp Post

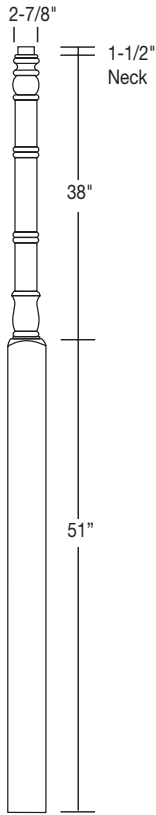

PermaPost Lamp Post Installation Instructions

1. Using post hole diggers dig hole in desired location (Refer to local building codes for post/footing depth).
2. Pre-run electrical wiring through steel pipe inside of post. Make sure wiring runs entire length of post with enough slack for fixture installation.
3. Set the post in hole and level. Fill remaining hole with compacted dirt or concrete.
4. Have a certified electrician install and connect all wiring for the lamp fixture.

FEATURES/NOTES:

- Galvanized pipe in center of lamp post allows for easy electrical feed and fixture connection.
- Weatherproof, rot and insect proof.
- Virtually maintenance free.
- Light fixture and wiring not included.

PAINT TIPS:

- PermaPost is made from a low maintenance white polyethylene that is designed to be left unpainted.

Chamfered Lamp Post

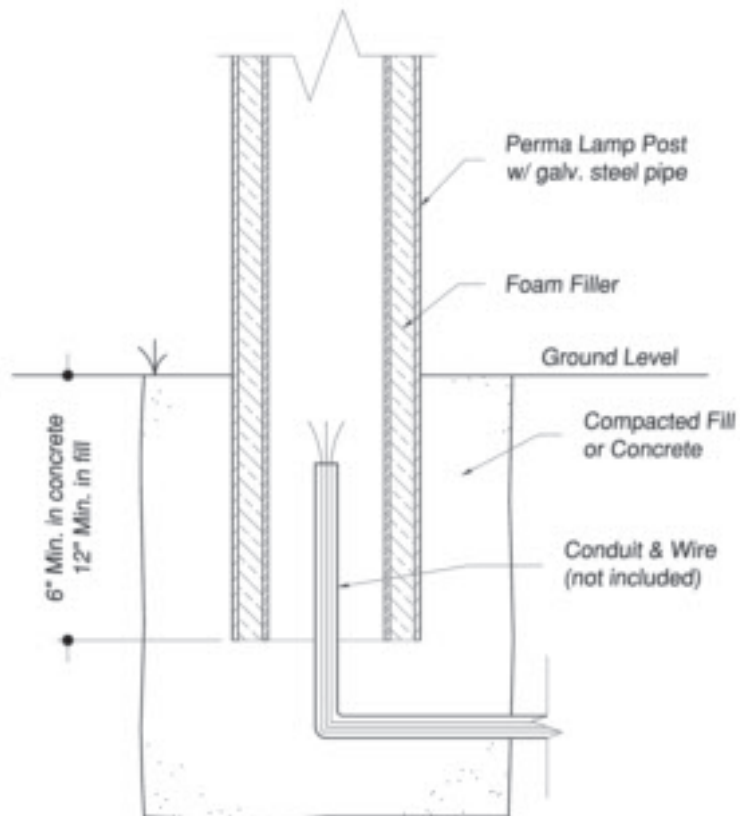
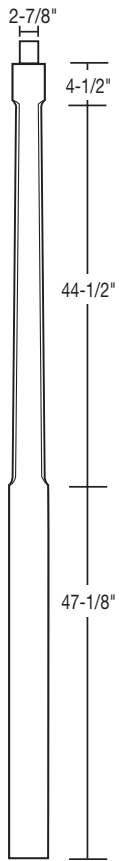

TYPICAL FOOTING SECTION FOR LAMP POST



Phone: (800) 264-4HBG
Fax: (334) 566-4629
www.hbgcolumns.com