

DIVISION: 06 00 00 – WOOD, PLASTICS AND COMPOSITES
Section: 06 03 11 – Plastic Railings

REPORT HOLDER:
HB&G BUILDING PRODUCTS, INC.
1015 Brundidge Boulevard
Troy, Alabama 36081
800-264-4424

www.hbgbuildingproducts.com

REPORT SUBJECT:
PermaRail Plus Railing
-Standard Top rail
-Newport Top Rail
-Savannah Top Rail
-Belhaven Top Rail

1.0 SCOPE OF EVALUATION

1.1 This Research Report addresses compliance with the following Codes:

- 2015 *International Building Code*® (IBC)
- 2015 *International Residential Code*® (IRC)

1.2 *PermaRail Plus* Railing has been evaluated for the following properties (see Table 1):

- Structural Performance
- Durability
- Surface Burning

1.3 *PermaRail Plus* Railing has been evaluated for the following uses:

- Guards under the definitions of the referenced codes intended for use on elevated walking areas in building and walkways, including stairs and ramps, as required by the referenced code.
- Provided as level guards for level walking areas such as decks, balconies, and porches, and as sloped guards for open sides of stairways.
- Guardrail systems recognized in this report may be used in One- and Two-Family Dwellings regulated by the IRC and all construction types regulated by the IBC in accordance with IBC Section 1406.3, Exception 2.

Guardrails less than 42 inches high are limited to use on One- and Two-Family Dwellings (IRC). See Table 1 for additional restrictions based upon Use and Occupancy classification.

2.0 STATEMENT OF COMPLIANCE

PermaRail Plus Railing complies with the Codes listed in Section 1.1, for the properties stated in Section 1.2 and uses stated in Section 1.3, when installed as described in this report, including the Conditions of Use stated in Section 6.0.

3.0 DESCRIPTION

3.1 *PermaRail Plus* railings are an assemblage of extruded polyvinyl chloride (PVC) rails, post sleeves, post mount guides, metal brackets, post mounts, foot blocks and aluminum reinforcements. The PVC components are produced in one color: White. The systems consist of the following components:

3.1.1 The *PermaRail Plus* railing system has four styles of top rails; *Standard*, *Newport*, *Savannah*, and *Belhaven*. The *Newport*, *Savannah*, and *Belhaven* top rail assemblies consists of two rails; the top rail is assembled over the inverted *Standard* rail. The *Standard* top rail is also used as a stand-alone top rail. See Figure 1 and 2 for guardrail assemblies and section profiles.

3.1.2 The infill area consists of 1-1/4" or 1-1/2" square, solid, extruded PVC pickets. See Figure 3.

3.1.3 All top and bottom rails include extruded aluminum inserts for reinforcement. See Figure 5.

3.1.4 Top and bottom rails are connected to posts using aluminum brackets for level assemblies and the articulated hinged bracket for stair assemblies. See Figure 6.

3.1.5 The *PermaRail Plus* railing systems are supported with LMT Angle Wizard Blu-Mount posts, LMT Angle Wizard galvanized posts, or conventional wood posts sleeved with 4.25" square PVC post sleeves. See Figures 4, 8 and 9.



4.0 PERFORMANCE CHARACTERISTICS

4.1 The *PermaRail Plus* Railing system described in this report have demonstrate the capacity to resist the design loading specified in Chapter 16 of the IBC and Section R301 of the IRC when tested in accordance with ICC-ES AC174.

4.2 Structural performance has been demonstrated for a temperature range from -20°F to 125°F.

4.3 Materials used are deemed equivalent to preservative treated or naturally durable wood for resistance to weathering effects, decay, and attack from termites.

4.4 Materials used in the *PermaRail Plus* Railing systems have a flame spread index not exceeding 200 when tested in accordance with ASTM E84.

5.0 INSTALLATION

PermaRail Plus Railing must be installed in accordance with the manufacturer's published installation instructions, the applicable Code, and this Research Report. A copy of the manufacturer's instructions must be available on the jobsite during installation.

5.1 Guardrail assemblies consist of top and bottom rails that include the U-channel aluminum railing reinforcements inserted in the rails. For rail lengths greater than 8 feet, a supplemental I-beam aluminum insert is required for the top rail.

5.1.1 Supplemental I-beam insert is placed within the U channel stiffener and fastened with a #8 x 2-1/2" screw through both stiffeners, the PVC top sub-rail and into every third baluster.

5.2 Decorative top railing snaps over the inverted *Standard* rail and reinforcement assembly with no mechanical fasteners. Siroflex DuoSil urethane acrylic adhesive caulk is used to permanently secure the decorative top railing.

5.3 Support blocks are installed based on rail length. A 6' foot rail requires one support block, the 8' and 10' rails require two support blocks, and the 12' rail requires three support blocks. Support blocks are installed beneath the bottom rail and equally spaced throughout the rail length.

5.4 Guardrail systems are secured to sleeved 4x4 wood posts, the *LMT Blu-Mount Angle Wizard* post mount, or *LMT*

Angle Wizard galvanized post mount with aluminum brackets and stainless steel screws. The wood in the supporting structure shall have a specific gravity of 0.50 or greater (Southern Yellow Pine or better) and a minimum thickness to allow full penetration of the bracket mounting screws. Rail attachment shall be in accordance with Table 2.

5.5 The *LMT Blu-Mount Angle Wizard* and *LMT Angle Wizard* galvanized post mounts may be anchored to wood or concrete.

5.6 Support posts are anchored to the supporting structure with four 5/16" inch diameter anchor bolts. The type and length of anchor bolts shall be suitable for the material and condition of the supporting structure. See Section 6.0 CONDITIONS OF USE for additional requirements.

6.0 CONDITIONS OF USE

6.1 Installation must comply with this Research Report, the manufacturer's published installation instructions, and the applicable Code. In the event of a conflict, this report governs.

6.2 See Section 1.3 for construction type(s) and use classification(s).

6.3 Conventional wood guardrail supports including 4x4 posts, and framing are not within the scope of this report and are subject to evaluation and approval by the building official. Supports must satisfy the design load requirements specified in Chapter 16 of the IBC. Supports and framing must provide suitable material for anchorage of the rail brackets and post mount, respectively. Where required by the building official, engineering calculations and details shall be provided.

6.4 Balusters are connected to the top rail with one of the two screws passes only through the inverted PVC *Standard* rail and the second screw passes first through the U-channel aluminum then through the inverted PVC *Standard* rail. See Figure 7.

6.5 Anchors and anchoring systems for use with the *LMT Blu-Mount Angle Wizard* and *LMT Angle Wizard* galvanized post mounts are not within the scope of this report and are subject to evaluation and approval by the building official. Anchors must satisfy the design load requirements specified in Chapter 16 of the building code and must meet the following minimum requirements:





6.5.1 A minimum of four anchor bolts must be used and located in the four pre-drilled holes in the post base plate.

6.5.2 The anchors must be stainless steel, galvanized steel or other approved material compatible with the post mount system.

6.5.3 The anchor bolts must have a minimum nominal diameter equal to 5/16" and utilize flat washers. The type and length of the anchor bolts are dependent upon the material and condition of the supporting structure and is not within the scope of this report.

6.5.4 When the supporting structure is a wood framed deck, installation must include anchorage to suitable structural framing. Decking is not considered structural framing, and anchorage to decking alone is not an approved installation method.

6.5.5 Where required by the building official, engineering calculations and details shall be provided. The calculations shall verify that the anchorage and supporting structure complies with the building code for the type and condition of the supporting construction.

6.6 Only those type of fasteners and fastening methods described in this report have been evaluated for installation with PermaRail Plus railing systems. Other methods of attachment are outside the scope of this report.

6.7 Compatibility of fasteners and other metallic components with the supporting structure, including chemically treated wood, is outside the scope of this report.

6.8 *PermaRail Plus* Railing is manufactured under a quality control program with inspections by Intertek Testing Services NA, Inc. (AA-676).

7.0 SUPPORTING EVIDENCE

7.1 Reports of testing and engineering analysis demonstrating compliance with the performance requirements of ICC-ES AC174, Acceptance Criteria for Deck Board Span Ratings and Guardrail Systems (Guards and Handrails), revised December 2014.

7.2 Reports of testing and engineering analysis demonstrating compliance with the performance requirements of ASTM D 7032-10a, Standard Specification for Establishing Performance Ratings for Wood-Plastic Composite Deck Boards and Guardrail Systems (Guards or Handrails).

7.3 Documentation of an Intertek approved quality system for the manufacturing of products recognized in this report.

8.0 IDENTIFICATION

PermaRail Plus Railing is identified with the manufacturer's name (HB&G Building Products, Inc.), address and telephone number, the product name (*PermaRail Plus* Railing). The label shall include the statements "See CCRR-0262 at whdirectory.intertek.com for uses and performance levels" and where applicable, "For Use in One- and Two-Family Dwellings Only.", the Intertek Mark as shown below, and the Code Compliance Research Report number (CCRR-0262).



9.0 OTHER CODES

This Section is not applicable

10.0 CODE COMPLIANCE RESEARCH REPORT USE

10.1 Approval of building products and/or materials can only be granted by a building official having legal authority in the specific jurisdiction where approval is sought.

10.2 Code Compliance Research Reports shall not be used in any manner that implies an endorsement of the product by Intertek.

10.3 Reference to the <https://bpdirectory.intertek.com> is recommended to ascertain the current version and status of this report.





TABLE 1 – GUARDRAIL SYSTEMS AND CODE OCCUPANCY CLASSIFICATIONS

Guardrail Type (All Styles)	Maximum Guardrail Dimensions ⁽¹⁾⁽²⁾	Support Post	Code Occupancy Classification
Level	96 in by 36 in	<i>LMT Angle Wizard galvanized</i> post mount for installation on Concrete or Wood -or- <i>LMT Blu-Mount Angle Wizard</i> post mount on Concrete or Wood -or- Conventional wood posts with post sleeves	The use of these products shall be limited to one- and two-family dwellings in accordance with the IRC and residential use groups under the IBC that permit construction in accordance with the IRC.
	144 in by 36 in	<i>LMT Angle Wizard galvanized</i> post mount for installation on Concrete or Wood -or- <i>LMT Blu-Mount Angle Wizard</i> post mount on Concrete or Wood -or- Conventional wood posts with post sleeves	
Level	96 in by 42 in	<i>LMT Blu-Mount Angle Wizard</i> post mount on Concrete -or- Conventional wood posts with post sleeves	IBC - All Use Groups IRC - One- and Two-Family Dwellings
	120 in by 42 in	<i>LMT Blu-Mount Angle Wizard</i> post mount on Concrete -or- Conventional wood posts with post sleeves	
Stair	96 in by 42 in	<i>LMT Blu-Mount Angle Wizard</i> post mount on Concrete -or- Conventional wood posts with post sleeves	

⁽¹⁾ Guardrails are qualified up to and including the listed maximum guardrail system dimensions for use in the referenced Code Occupancy Classification. Guardrail lengths are actual railing lengths, i.e. clear space between supports for level rails and sloping length of rail between supports for stair rail.

⁽²⁾ Guardrail lengths of greater than 8 feet require a U-channel aluminum insert in top and bottom rails, and an I-Beam supplemental reinforcement in top rail. Guardrail lengths of 8 feet or less require a U-channel aluminum insert in top and bottom rails.





TABLE 2 – FASTENING SCHEDULE

Connection	Fastener
Top and Bottom Rail Bracket to Support Structure	<u>For Conventional Wood Posts:</u> Three 1/4"-10 x 2-1/2" stainless steel hex-washer head fasteners
	<u>For Post Mounts:</u> Three 1/4"-10 x 1-1/4" stainless steel hex-washer head fasteners
Top Rail Bracket to Rail	One 1/4"-20 x 1" flat-head capped bolt with corresponding nut for attachment to rail
Bottom Rail Bracket to Rail	One 1/4"-20 x 3/4" flat-head capped bolt with corresponding nut for attachment to rail
I-Beam Supplemental Reinforcement to Top Rail for rails over 8'	One #8 x 2-1/2 screw into every third picket
Balusters to Top Rail	Two #8-15 x 2-1/2" stainless steel flat-head screws (0.114 in minor dia.)
Balusters to Bottom Rail	One #8-15 x 2-1/2" stainless steel flat-head screw (0.114 in minor dia.)
Support Block to Bottom Rail	One #8-15 x 2-1/2" stainless steel flat-head screw (0.114 in minor dia.)
Stair Bracket Hinge Connection	One #5-20 x 1/2" (0.098 in minor diameter) Philips drive, pan head, stainless steel screw with washer at each end of hinge

This Code Compliance Research Report ("Report") is for the exclusive use of Intertek's Client and is provided pursuant to the agreement between Intertek and its Client. Intertek's responsibility and liability are limited to the terms and conditions of the agreement. Intertek assumes no liability to any party, other than to the Client in accordance with the agreement, for any loss, expense or damage occasioned by the use of this Report. Only the Client is authorized to permit copying or distribution of this Report and then only in its entirety, and the Client shall not use the Report in a misleading manner. Client further agrees and understands that reliance upon the Report is limited to the representations made therein. The Report is not an endorsement or recommendation for use of the subject and/or product described herein. This Report is not the Intertek Listing Report covering the subject product and utilized for Intertek Certification and this Report does not represent authorization for the use of any Intertek certification marks. Any use of the Intertek name or one of its marks for the sale or advertisement of the tested material, product or service must first be approved in writing by Intertek.



Intertek

545 E. Algonquin Road • Arlington Heights • Illinois • 60005
intertek.com/building



ACCREDITED
 Product
 Certification Agency
 PCA-101

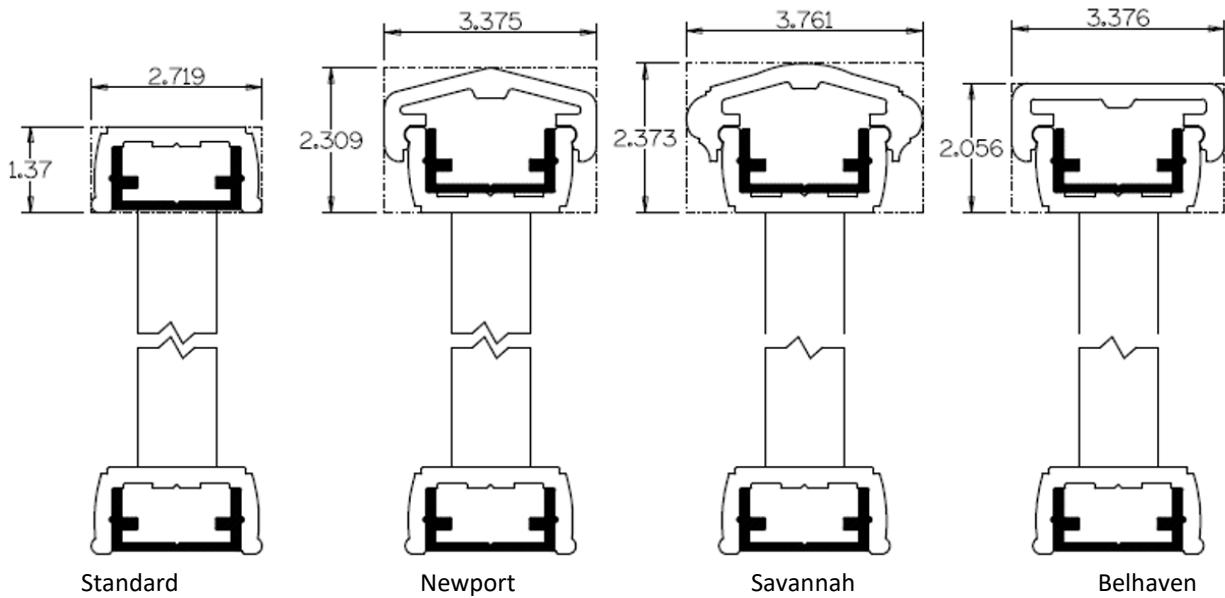

FIGURE 1 – GUARDRAIL ASSEMBLIES

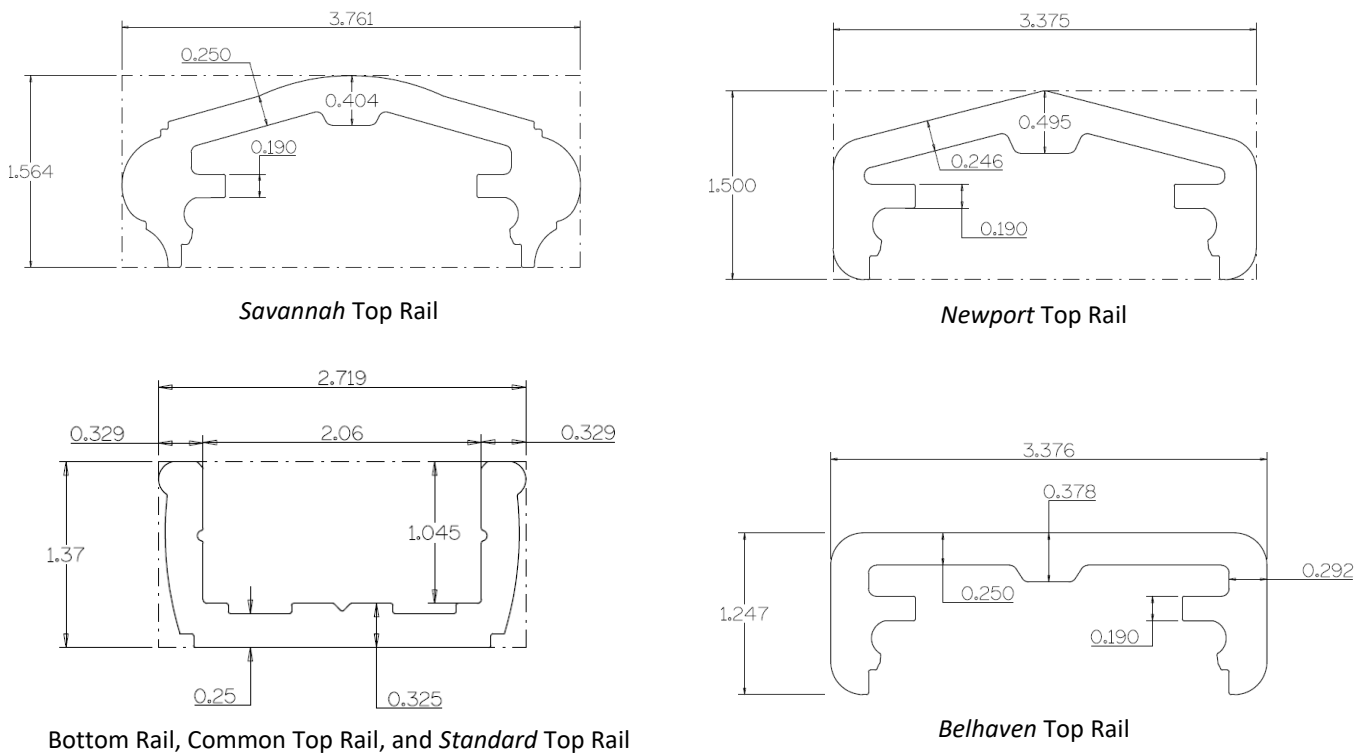

FIGURE 2 – TOP CAP PROFILES





FIGURE 3 – PICKETS

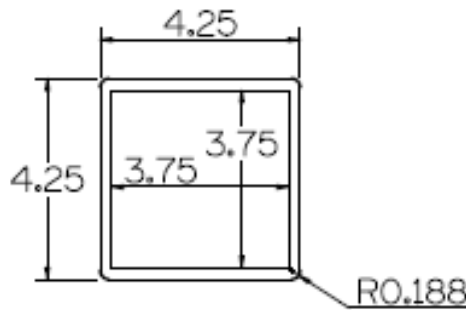

FIGURE 4 – 4.25" SQUARE NEWEL POST SLEEVE

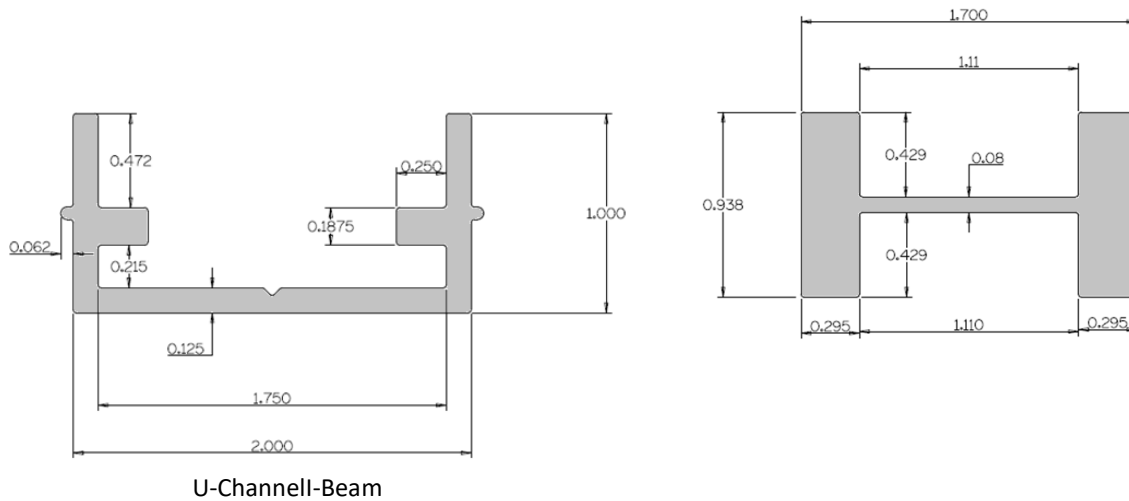
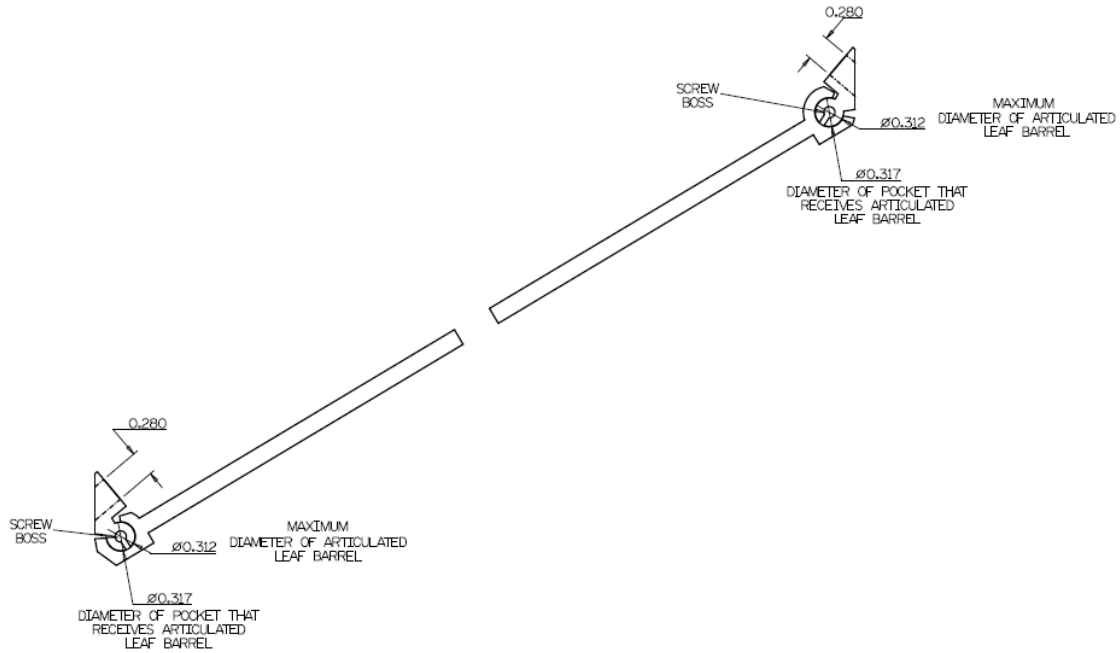
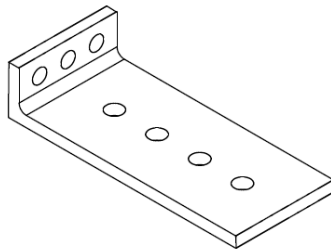

FIGURE 5 – ALUMINUM REINFORCEMENTS





Articulated Rail Bracket (Stair)



Level Rail Mounting Bracket

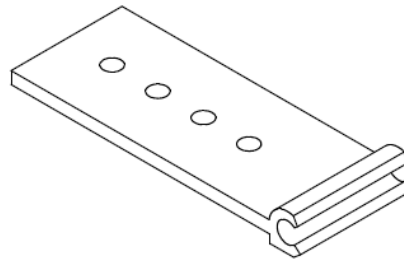

Top Rake Bracket

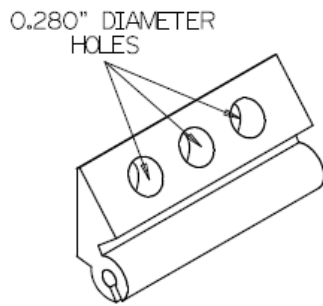

Rake Bracket Hinge

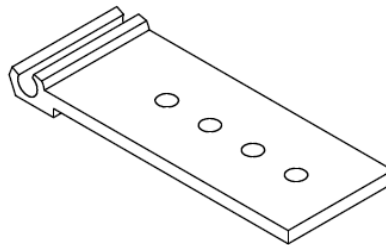

Bottom Rake Bracket

FIGURE 6 – BRACKETS



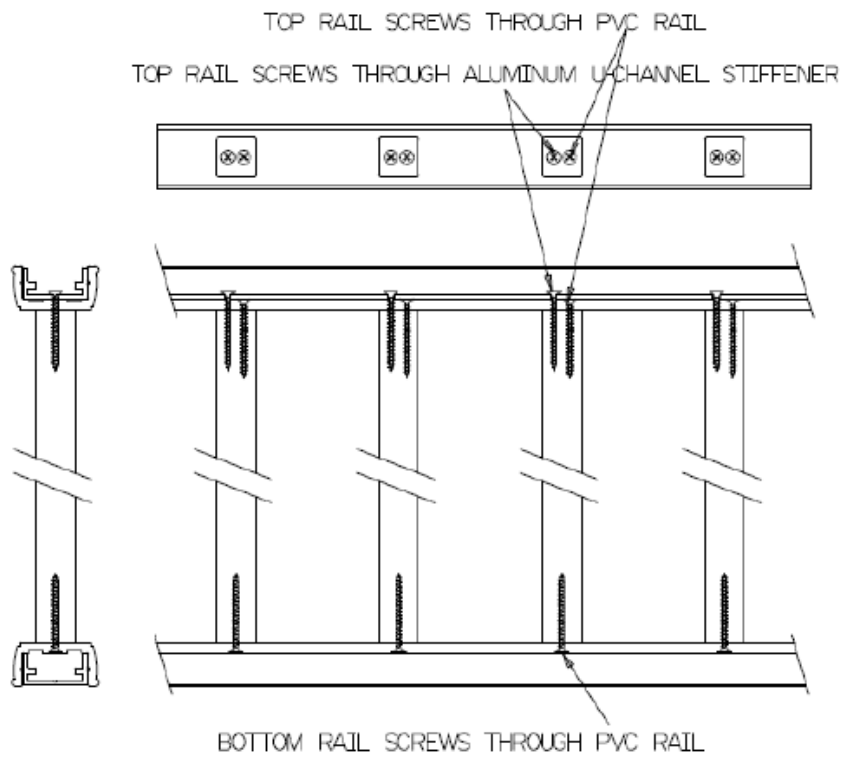
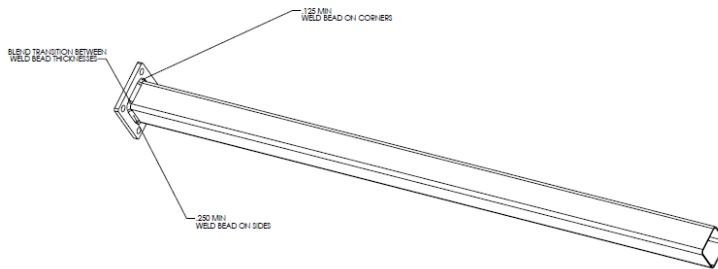
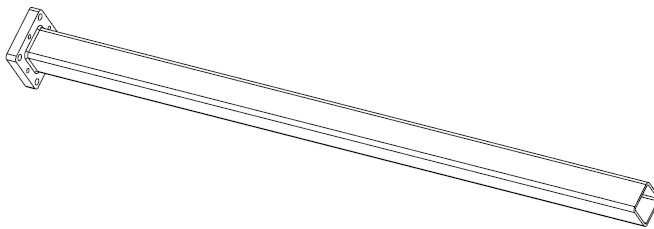
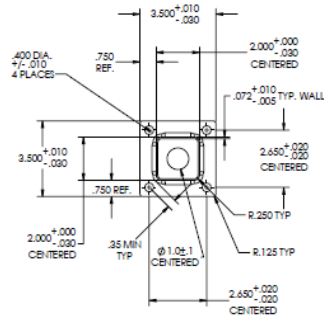

FIGURE 7 – INSTALLATION OF BALUSTERS



LMT Angle Wizard Galvanized Post



LMT Blu-Mount Angle Wizard Post

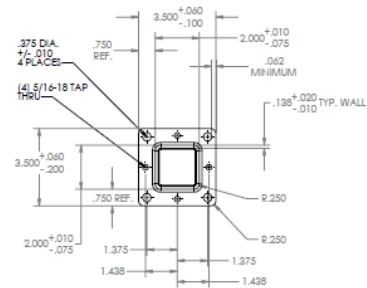

FIGURE 8 – POST MOUNTS

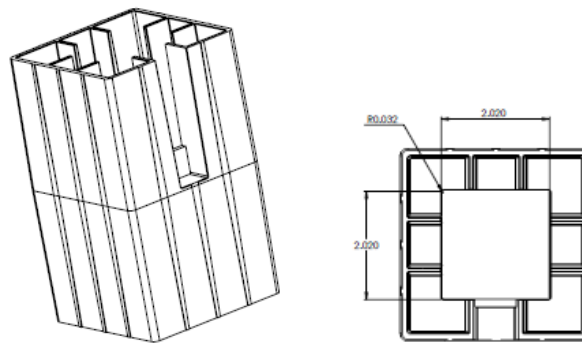

FIGURE 9 – LMT PVC POST MOUNT GUIDE